

REVISION HISTORY			
REV	DESCRIPTION	DATE	AUTHOR
A	Endret tekst	06.05.2019	MM

1. Merk hull posisjon

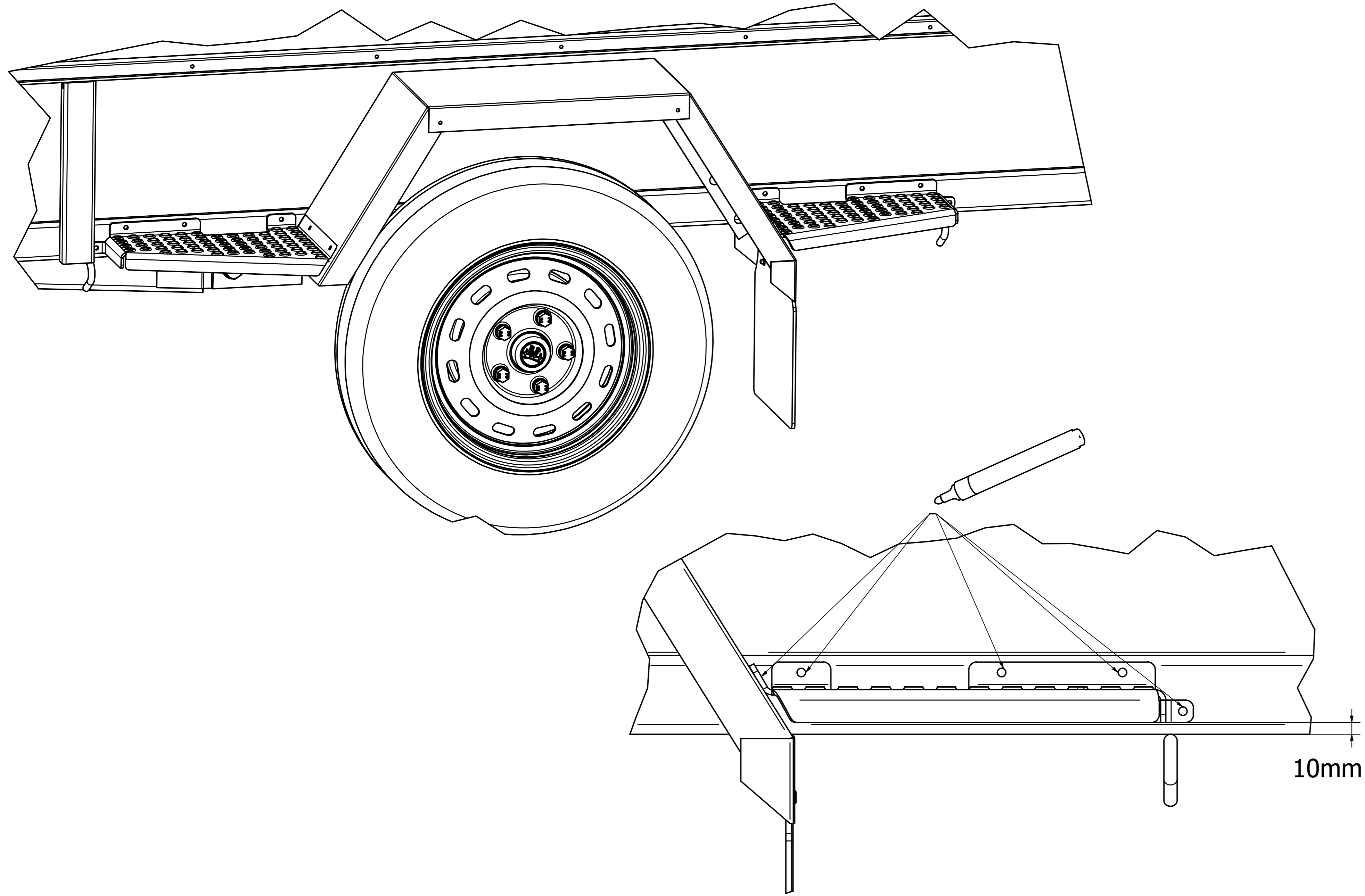

2. Bor hull Ø5mm

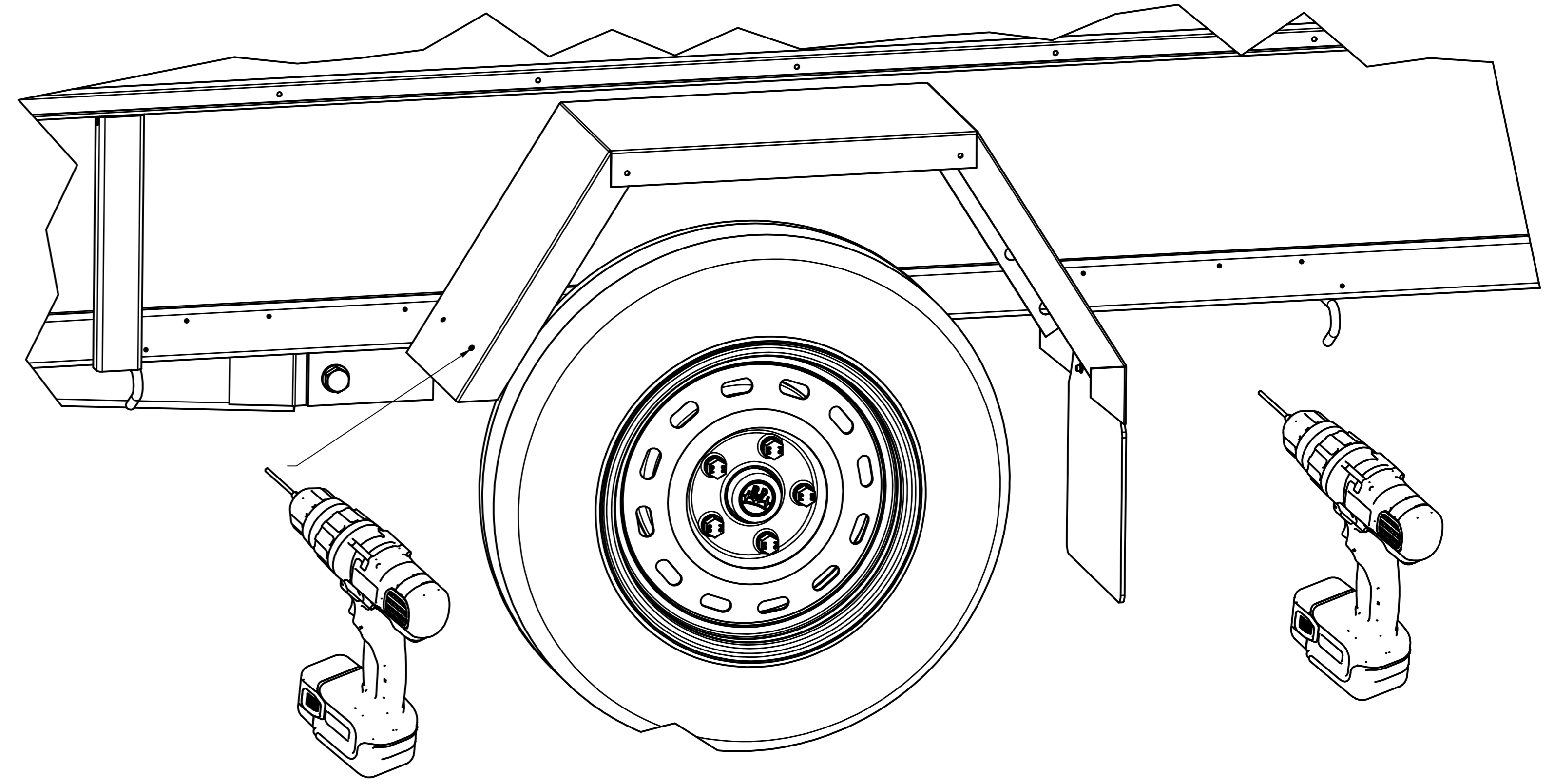

3. Bolt trinn

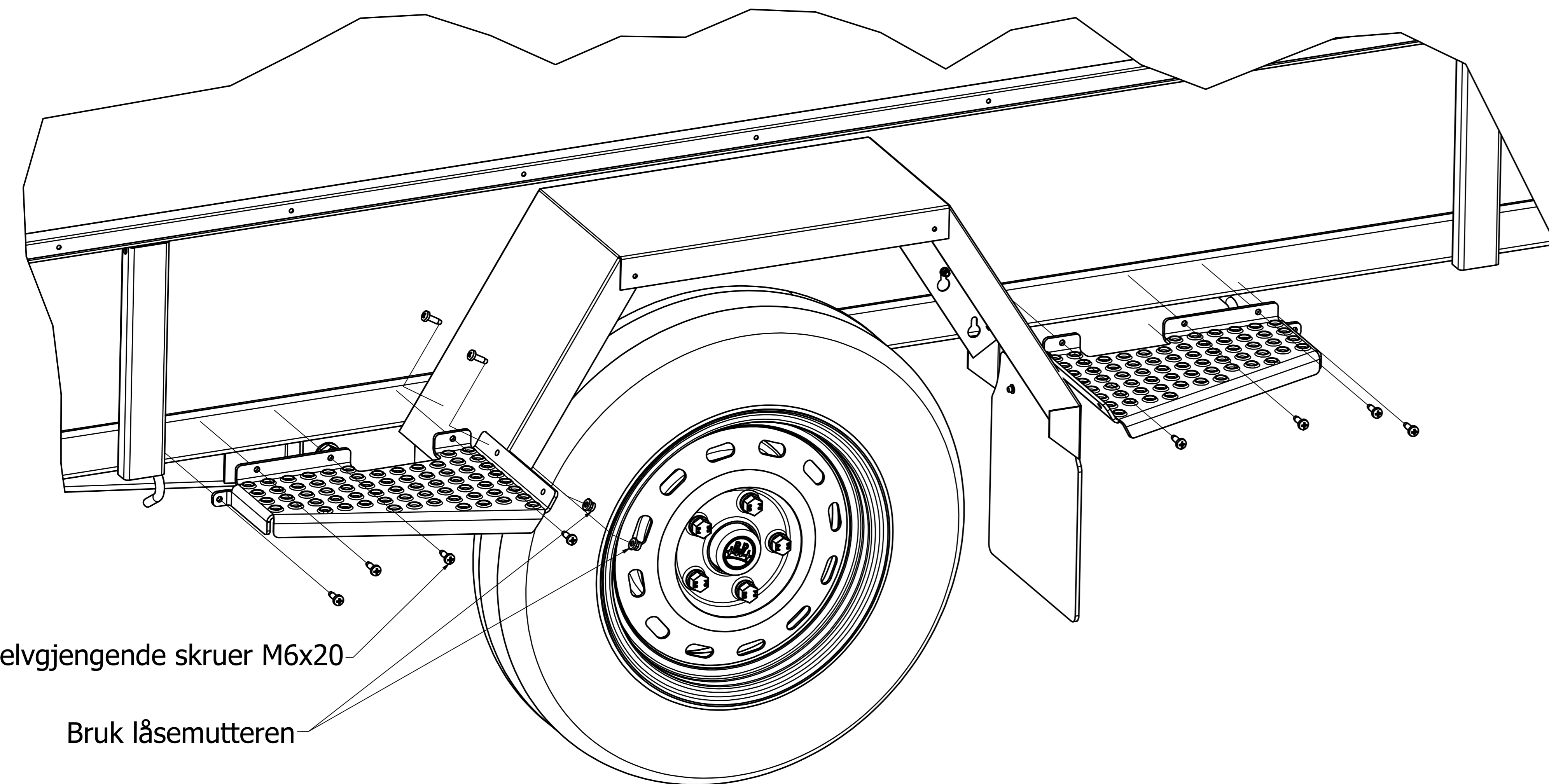

4. Ferdig

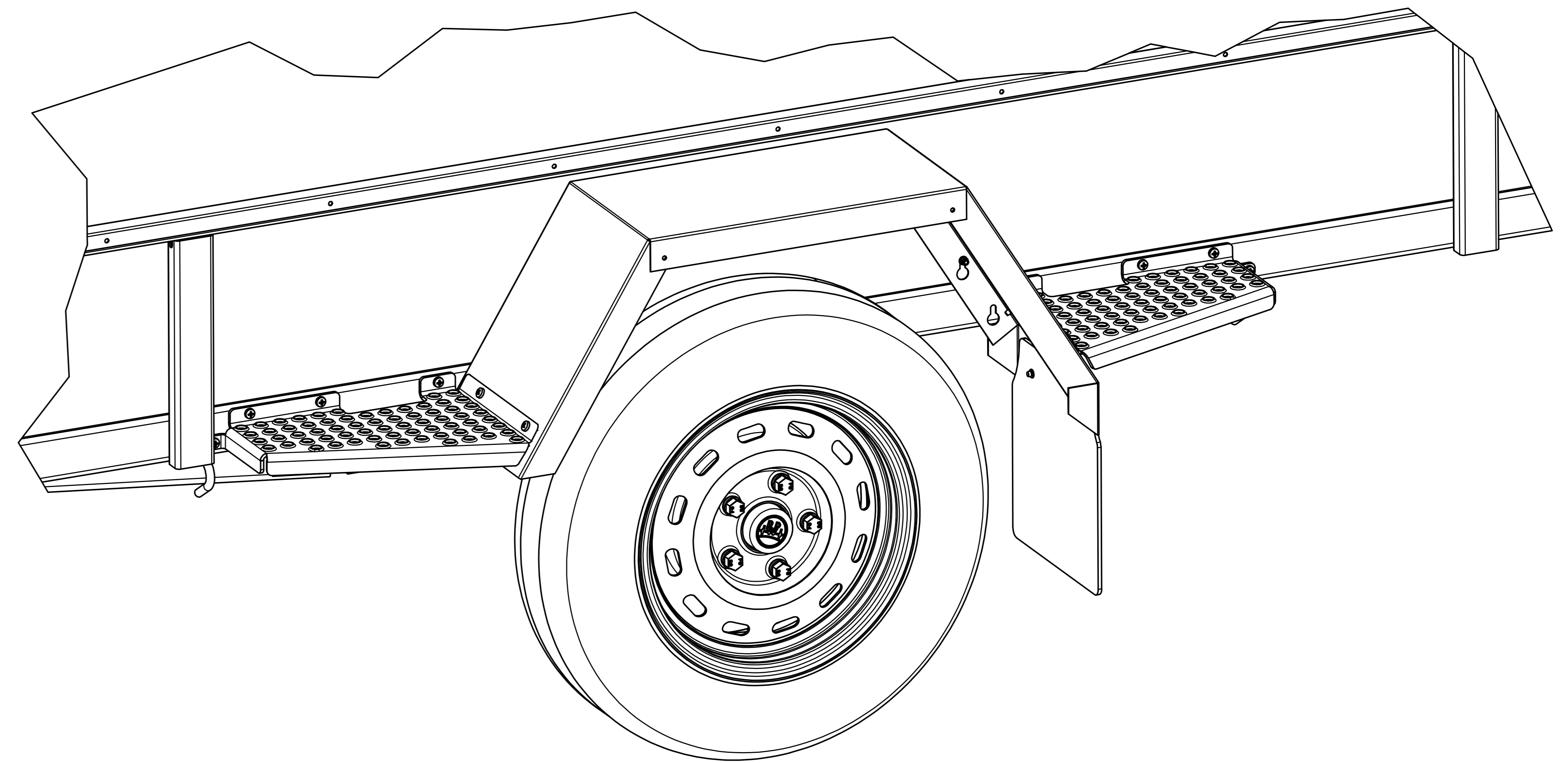

GENERAL NOTE:
 - Tolerances according to ISO 2768 - medium if nothing else specified.
 - Hot Dip Galvanization according to ISO 1461
 - Electro Galvanization according to ISO 1461
 - Power Coating according to ISO 2380

Created by	MM	Creation Date	15.04.2019	Total Pages	N/A	Format	A0	Scale	1:6	Sheet of Sheets	1 / 1
											
Title: Montering stigtrinn instruksjon Utility Trailers Part Number (Drawing): NK Drawing Number: IN108479 Rev: A											